

POSITIVE

WEIGHING SOLUTIONS

SERVICE • INDUSTRIAL • AUTOMATION • LOGISTICS

Dimension® Flex Series

PARCEL AND PALLET DIMENSIONING SYSTEMS

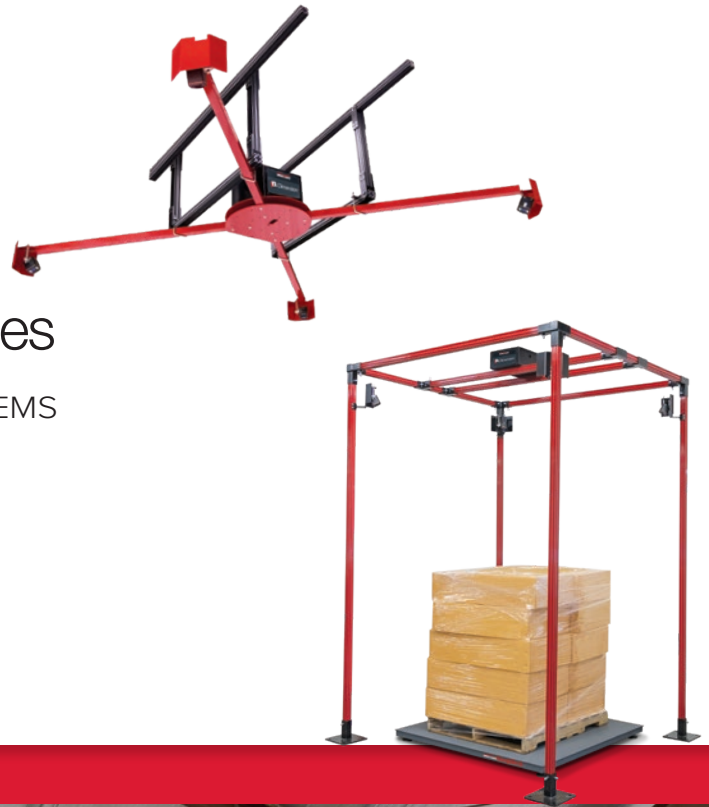

RICE LAKE[®]
WEIGHING SYSTEMS

800-472-6703

www.ricelake.com

Flexible Dimensioning System

The iDimension Flex Series brings state-of-the-art dimensioning technology to shipping and logistics professionals. Ensure accurate dimensions on your bill of lading and protect against costly invoice corrections from LTL carriers by integrating automatic dimensioning systems.

Freight Dimensioning Benefits

1

RELIABLE
CHARGEBACK
PREVENTION

2

DOCUMENTATION
AND IMAGES FOR
FREIGHT CLAIMS

3

CERTIFIED LEGAL FOR
TRADE DIMENSIONS

4

STREAMLINED
OPERATIONS

Free-standing



Suspended



Installation Options

The iDimension Flex Series is available in two different configurations: free-standing and suspended. Both versions provide clear access to the dimensioning zone. When the iDimension Flex is installed above a conveyor or pallet stretch wrapper, you can efficiently wrap, weigh and dimension freight in one step.

A center sensor can be added to the junction box on iDimension Flex systems to accurately capture dimensions of freight wrapped in black plastic.

FLEXIBLE CONFIGURATION

The iDimension Flex Series is available with four or five sensors to measure cuboidal or irregular freight. The system can be suspended from the ceiling or be free-standing to meet the needs of your operation. A two-sensor version can also be installed above a conveyor to dimension parcels longer than 48 inches.

CLAIMS DEFENSE

When shipment dimensions are measured, the iDimension Flex also captures color images to record shipment condition before it leaves your facility. These images can then be used to hold freight carriers accountable for any damages.

Free-standing iDimension Flex

System installed above a wrapper and conveyor line to streamline processing

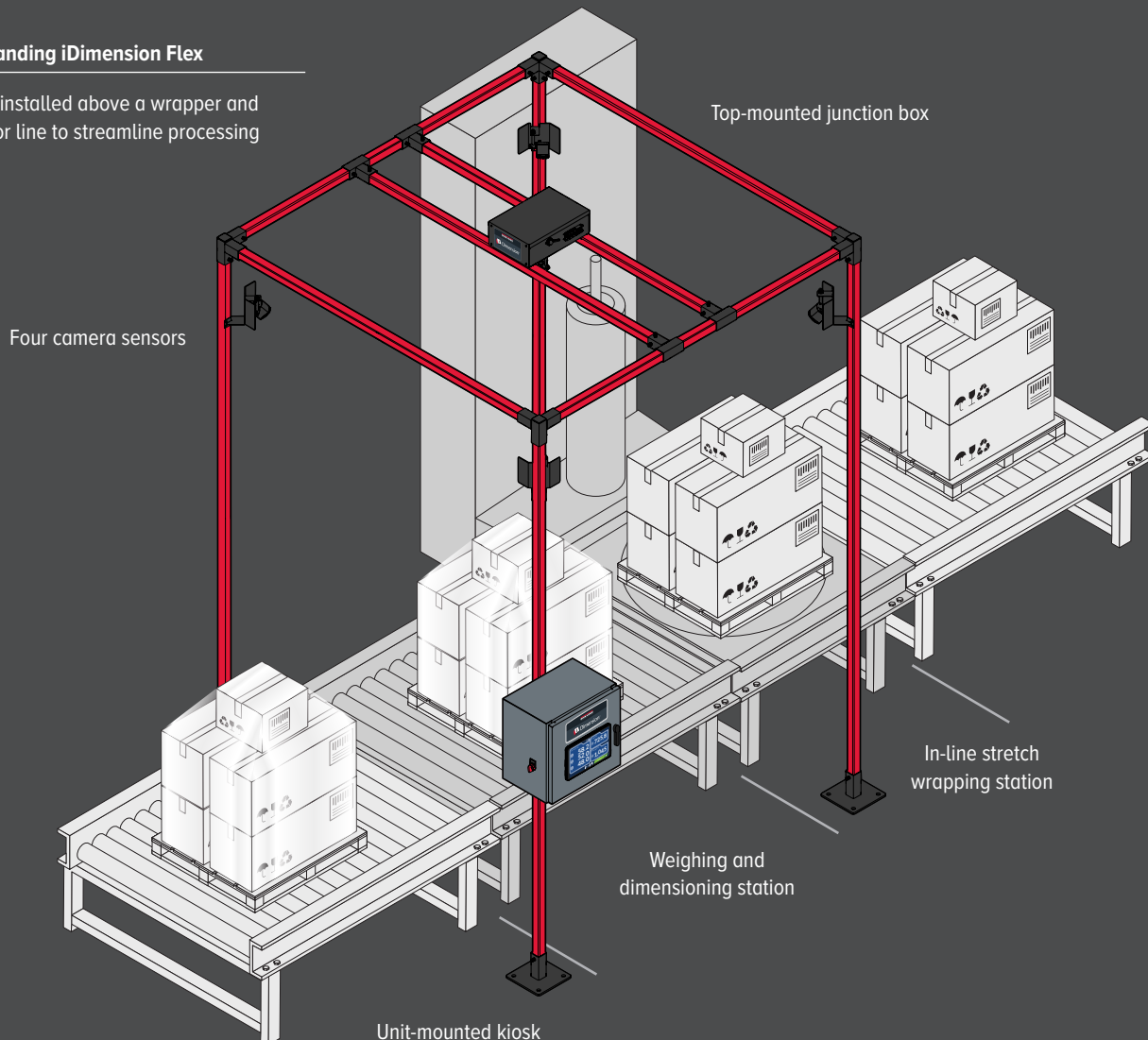

CERTIFIED LEGAL FOR TRADE

iDimension Flex systems provide OIML and NTEP Certified Legal for Trade dimensions for best-in-class accuracy. Carriers are less likely to audit freight that is measured with Legal for Trade dimensioners, which increases efficiency in their operations and may lead to savings for shippers.

Suspended iDimension Flex

System installed above operations to ensure easy forklift traffic flow and prevent equipment damage

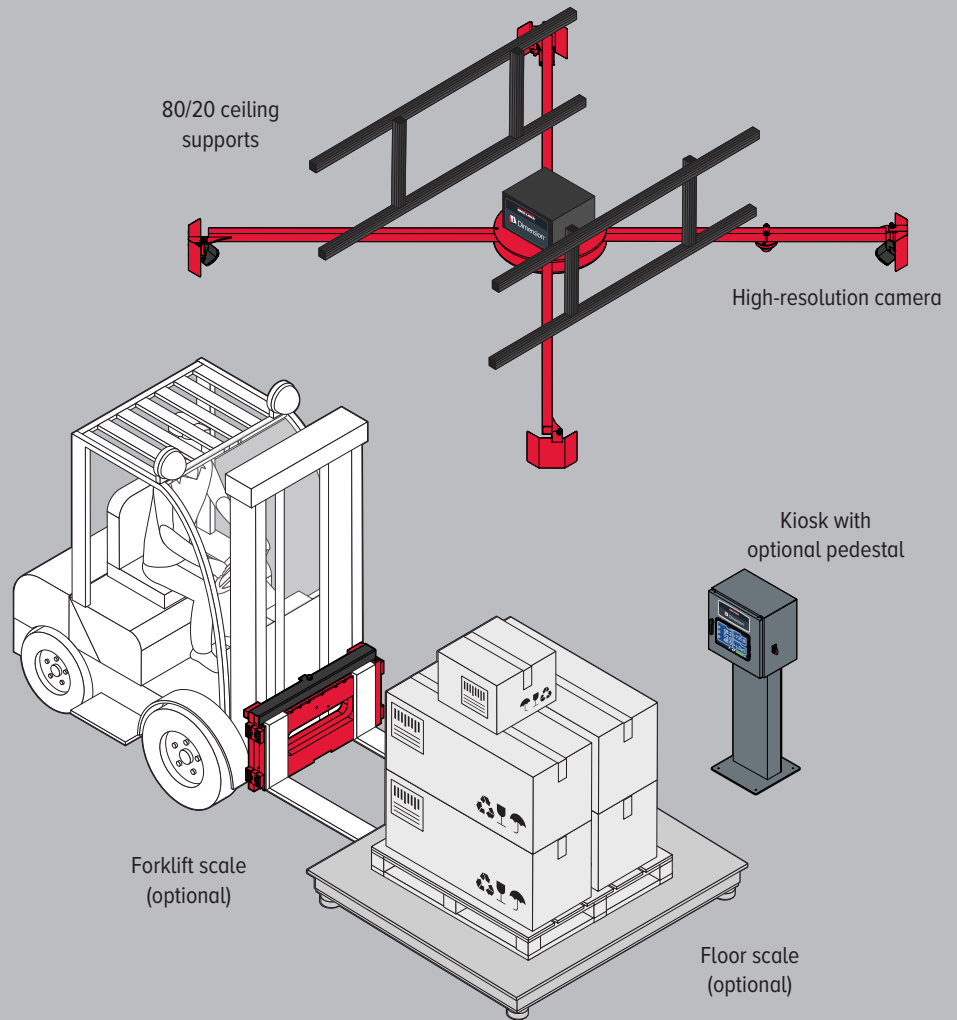

Robust Software

Integration That Works

The iDimension Flex has a comprehensive network interface for straightforward integration to your network and shipping software. Trigger iDimension Flex to capture measurements from the kiosk touchscreen or with a REST API call or bar code scanner.

Use a bar code scanner to read the sales order or other pallet identification number. A label printer can print time/date, ID and freight data.

Export images and shipment data using FTP or SMB protocols, or use REST APIs to customize your data collection process.

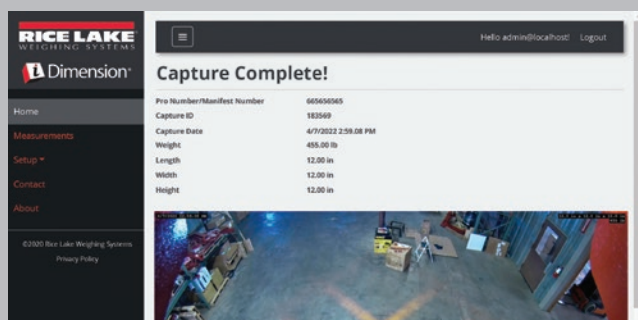



iDimension Flex can be installed in a variety of shipping environments, even where space is limited.

DIMENSIONING
IN LESS THAN
2.0
SECONDS

iDimension® Flex Series

PARCEL AND PALLET DIMENSIONING SYSTEMS

DISPLAY KIOSKS

Operator kiosks can be wall-mounted, unit-mounted or attached to a pedestal base so it is clear of any forklift traffic and other hazards. Kiosks have a 10.5-inch color touchscreen display so dimensions and weight are clearly visible.



COMPLETE YOUR SYSTEM

Complete your iDimension Flex system by adding a scale, bar code scanner and printer to record accurate freight dimensions and ensure accurate pricing.

OPTIONS

- FLOOR SCALE
- BAR CODE SCANNER
- PRINTER
- SECOND COLOR CAMERA
- ADDITIONAL 5TH SENSOR FOR BLACK PLASTIC
- PEDESTAL BASE FOR KIOSK
- MOUNTING CONFIGURATION FOR SUSPENDED SYSTEM

SPECIFICATIONS

POWER REQUIREMENTS:	96 to 264 VAC 25 ft (7.62 m) U.S. power cable included
MEASUREMENT RANGE	Maximum freight size: (L × W × H) 72 × 72 × 96 in (1,829 × 1,829 × 2,438 mm) Minimum freight size: 12 × 12 × 12 in (305 × 305 × 305 mm)
COMMUNICATION PORTS:	Ethernet TCP/IP, USB, RS-232
OPERATING TEMPERATURE:	14 °F to 104 °F (-10 °C to 40 °C)
HUMIDITY:	0 to 90% non-condensing
WARRANTY:	Two-year limited Five-year limited, sensors only

APPROVALS:



POSITIVE
WEIGHING SOLUTIONS

01684 561002

SERVICE • INDUSTRIAL • AUTOMATION • LOGISTICS

Unit 8 The Clifton Centre
Spring Lane South
Malvern
WR14 1BJ

RICE LAKE
WEIGHING SYSTEMS

