

TPWLKW "LOGISTIC" SERIES PALLET TRUCK SCALE WITH WIDE FORKS



Pallet truck scale, with built-in electronic weighing, fitted with forks 680mm width, which making it ideal for the handling of pallets in the Food & Chemical Industry Sector. Fitted with rechargeable extractable battery. Available also with a built-in printer as well as CE-M DOUBLE RANGE approved.

TPWLKW pallet truck scale fitted forks 680mm width.

MAIN FEATURES

- Maximum lifting capacity: 2000 kg.
- Accuracy: +/- 0.1% of the maximum capacity in the versions for internal use.
- Accuracy: +/- 0.05% of the maximum capacity in the "M" approved versions.
- **Forks dimensions 1240 x 680 x 85 mm.**
- Weighs about 134 kg.
- Structure in extra thick steel and oven-fire painted mechanics.
- Steering wheels and double loading poliurethane rollers.
- 4 stainless steel IP68 load cells for the legal for trade use version, aluminium IP54 load cells for the internal use version.
- High contrast digits, which are clearly visible even in poor lighting conditions and with low temperatures, and waterproof membrane keyboard, with 17 functional keys.
- **Configuration, calibration and diagnostics from keyboard or PC with DINITOOLS.**
- Power supply through extractable rechargeable battery mounted on the pallet truck column.

- The operating time is of about 80 hours of continuous use or one month with the typical non continuous use, thanks to its auto switch-off function.
- Programmable auto power saving function. Battery level indication.
- Equipped with 230Vac 50 Hz battery charger (recharging time is about 8 hours).
- Configurable RS232/C bidirectional port for **connection to a printer, with customisable print format.**
- Configurable RS232/C bidirectional port for PC, modem radio or portable terminal.
- IR input for remote control management.
- **Fitted with thermal printer in the TPWLKWP and TPWLKWPM versions, with Date & Time card.**

Weight indicator in IP65 **STAINLESS STEEL waterproof case**, which is easy to clean and resistant to harsh and corrosive environments; **large 25mm LCD display high**

MAIN FUNCTIONS

- Zeroing, Tare, Printing
- **High Resolution Weighing x 10**
- **Net/Gross or lb/kg conversion**
- **Accumulation**
- **Formulation**
- **+/- Checkweighing**
- **Percentage weighing**
- **Counting** (Max. resolution of 1.500.000 divisions)
- **Hold and Peak**

Set Point Control (with optional interface)

AVAILABLE UPON PRICE ESTIMATE

- Special steering wheels.
- Special fork length from 850 to 1500 mm.
- Special capacity e/o divisions
- High resolution

TPWLKW Pallet Truck Dimensions

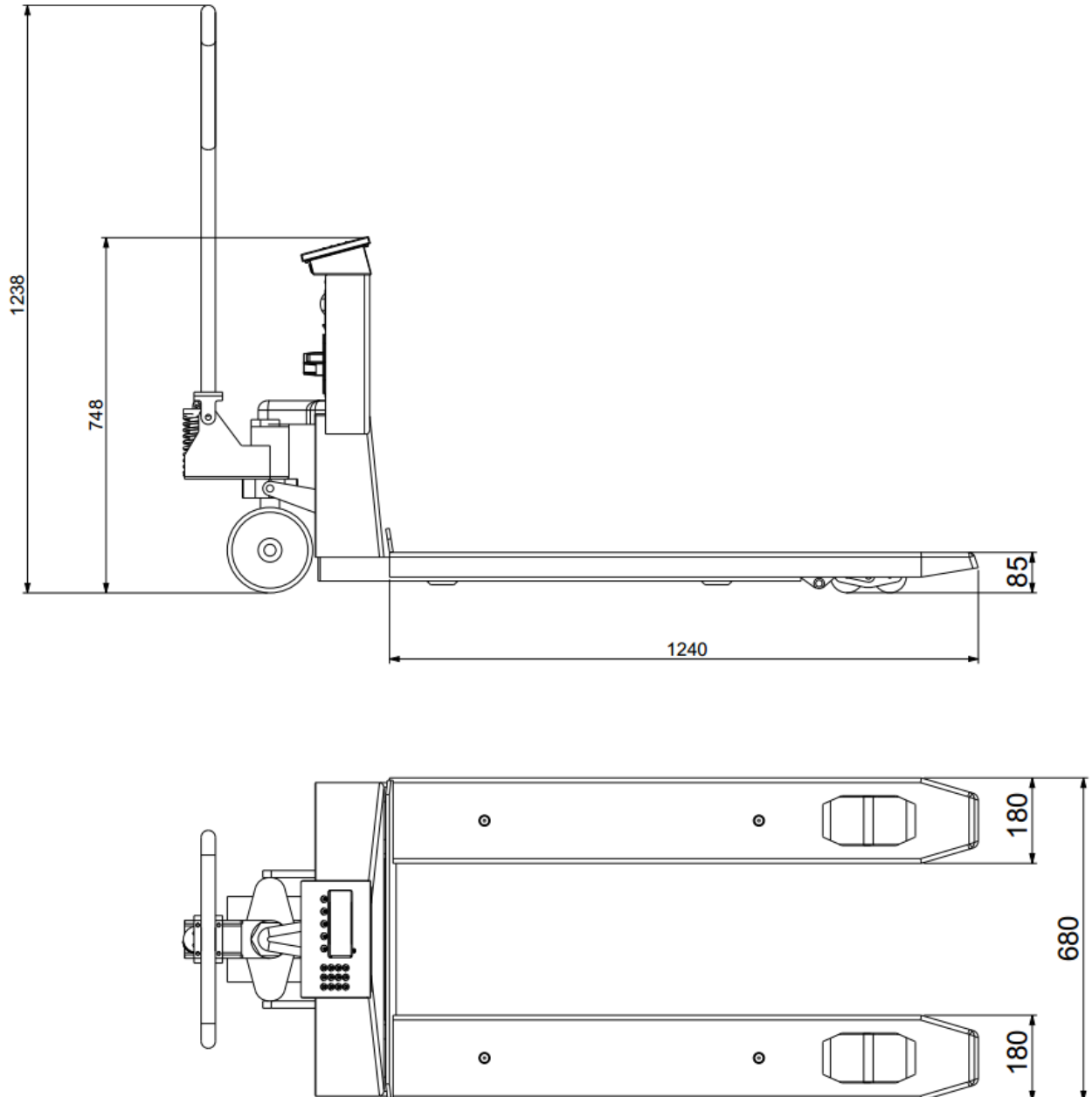

RETAIL • INDUSTRIAL • BAGGING • SERVICE

0845 504 5335
enquires@positiveweighing.co.uk
positiveweighing.co.uk

Unit 8 The Clifton Centre
Spring Lane South
Malvern
WR14 1BJ

Company Reg. No. 4936597
VAT No. 769648756

RETAIL • INDUSTRIAL • BAGGING • SERVICE