

# STABICAN 200T

100 t ... 200 t

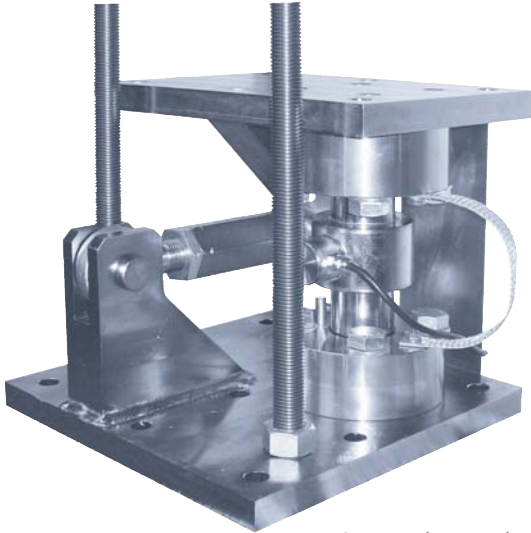

Capteur et plaques vendus séparément  
Load cell and plates sold separately

- Conçu pour le pesage de cuves et trémies
- Disponible en acier zingué
- Stabilisation à rotules intégrée
- Dispositif d'anti-soulèvement
- Conception compacte et installation facile
- Jeux et débattements réglé en usine
- *Designed for high capacity tank or silo weighing*
- *Zinc plated or stainless steel construction*
- *Integrated stabilization rods*
- *Lift-off prevention system*
- *Compact design for easy installation*
- *Spacings set up in factory*

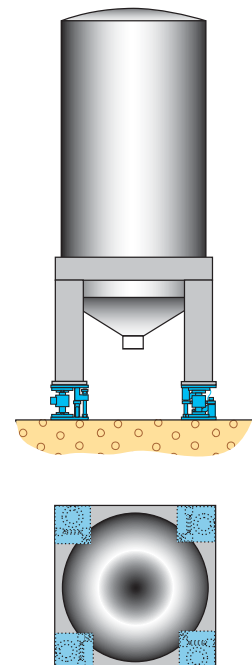
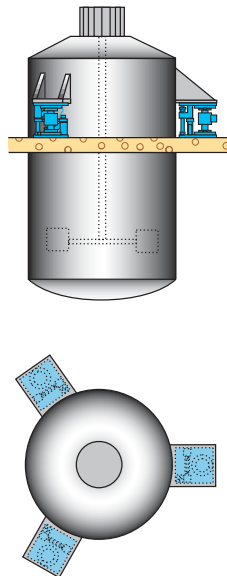
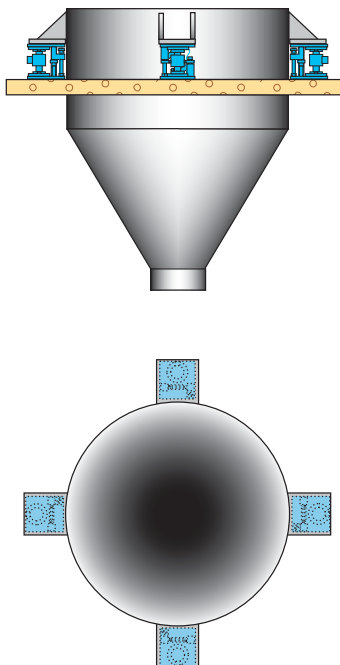

Toutes dimensions en mm. Dimensions et spécifications non contractuelles. Dessins techniques disponibles sur demande.  
All dimensions in mm. Dimensions and specifications do not constitute any liability whatsoever. Technical drawings are available on request.



# STABICAN 200T

100 t ... 200 t

## Dimensions - Dimensions

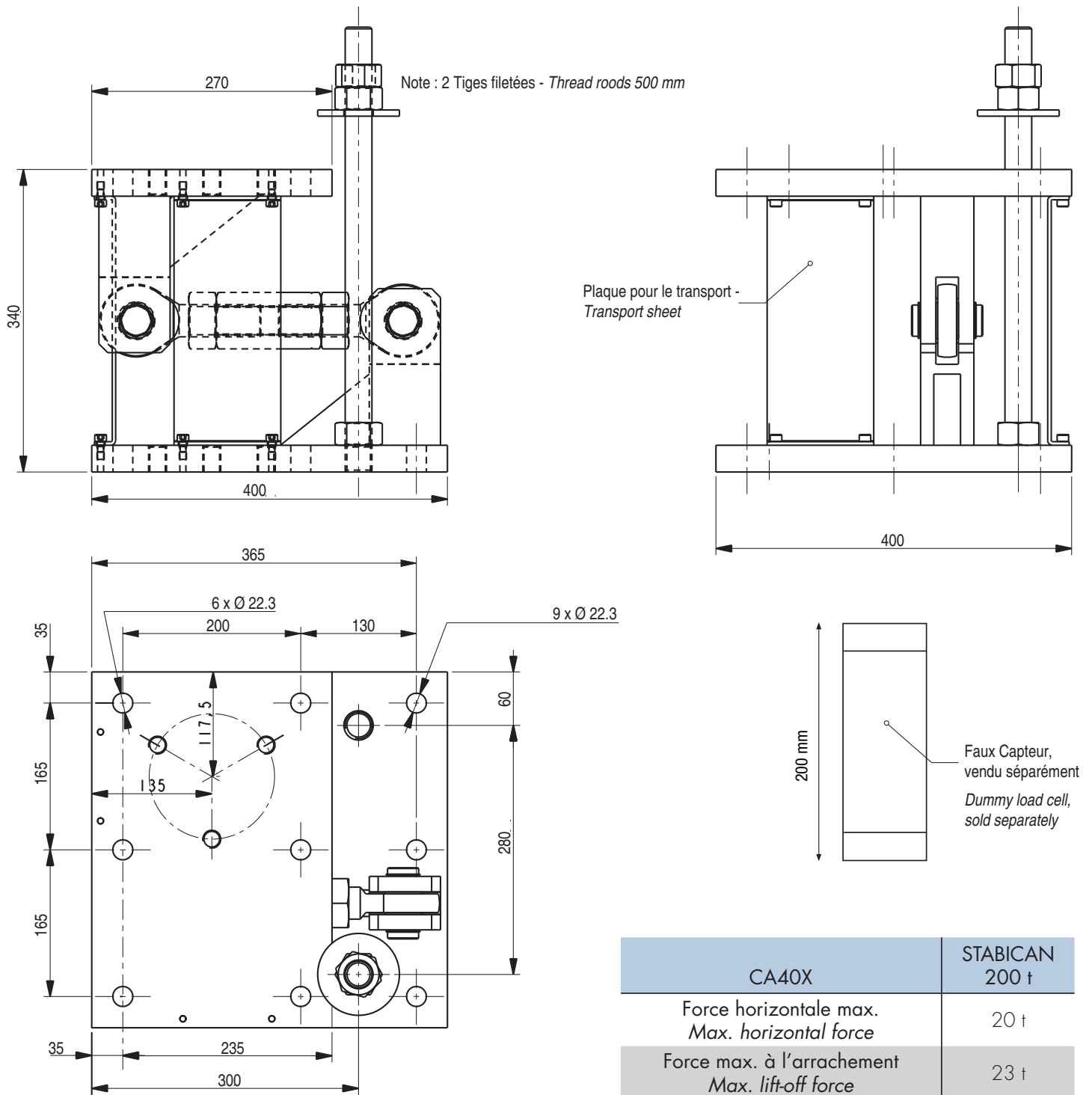

Siège Social - Headquarter: Technosite Altéa - 294, Rue Georges Charpak - 74100 JUVIGNY - FRANCE  
 SCAIME SAS - 294, RUE GEORGES CHARPAK - CS 50501 - 74105 ANNEMASSE CEDEX - FRANCE  
 Tél. : +33 (0)4 50 87 78 64 - Fax : +33 (0)4 50 87 78 46 - info@scaime.com - [www.scaime.com](http://www.scaime.com)  
 Téléchargez tous nos documents sur notre site internet - Download all our documents on our website

