

# R10X

## 250 kg ... 100 t



- Réalisé en inox soudé IP68
  - Précision jusqu'à  $\pm 0.05\%$
  - Bouton de charge sphérique
  - Idéal pour les applications de pesage de cuves ou silos
  - Très facilement nettoyable
  - Version haute température (HT :  $+130^{\circ}\text{C}$ ) sur demande
  - Option sortie connecteur
- Made of stainless steel, sealed IP68
  - Accuracy up to  $\pm 0.05\%$
  - Spherical load button
  - Ideally suited for tank or silo weighing applications
  - Easy to clean
  - High temperature version (HT :  $+130^{\circ}\text{C}$ ) on request
  - Optional connector output



\* En option, uniquement sur version câble - In option, only for cable version

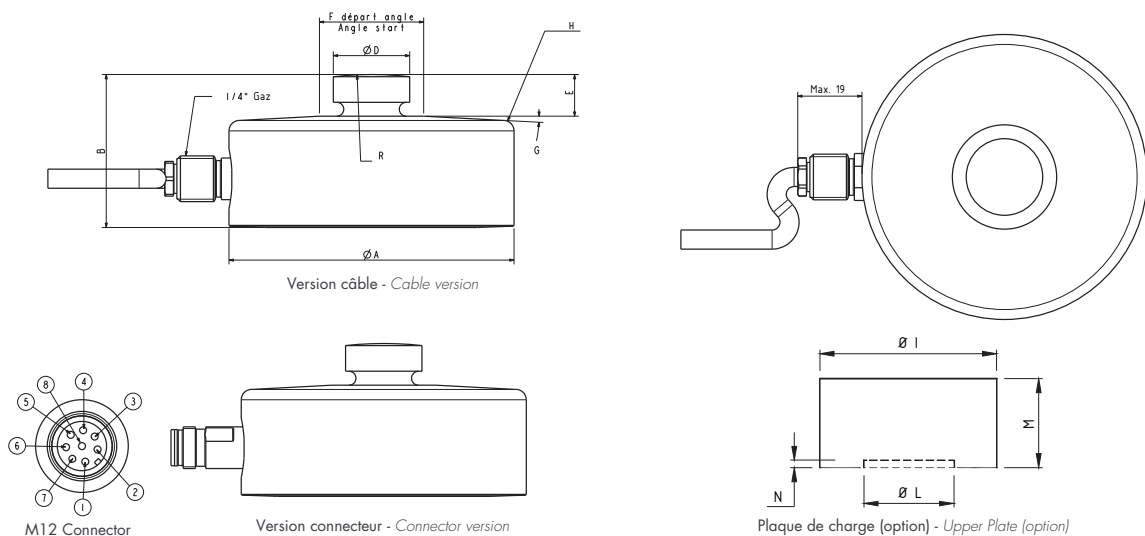

Capacité Nominal Rated capacity (C.N.)	Dimensions - Dimension [mm]												Poids Weight
	$\varnothing A$	B	$\varnothing D$	E	R	F	G	H	$\varnothing I$	$\varnothing L$	M	N	
250 kg ... 15 t	82	44	22	12	90	30	3°	3	82	23	15	3	1.5 kg
30 t	126	54	35	14	160	55	3°	3	89	36	15	3	4 kg
50 t S-Size	126	54	35	14	160	55	3°	3	89	36	25	3	4 kg
50, 100 t	164	80	60	20	340	/	0°	0	89	62	25	4	10 kg

Toutes dimensions en mm. Dimensions et spécifications non contractuelles. Dessins techniques disponibles sur demande.  
All dimensions in mm. Dimensions and specifications do not constitute any liability whatsoever. Technical drawings are available on request.

### Câblage - Wiring

+ alim.	+ signal	- signal	- alim.
+ excit.	+ signal	- signal	- excit.
rouge	vert	blanc	noir
red	green	white	black

### Câblage version connecteur - Wiring connector version

+ alim.	+ signal	- signal	- alim.	+ réf.	- réf.
+ excit.	+ signal	- signal	- excit.	+ sense	- sense
7	1	8	6	3	5



# R10X

250 kg ... 100 t

## Caractéristiques - Specifications

MÉTROLOGIQUES	METROLOGICAL				
Capacité nominale (Cn)	Rated capacity (Cn)	0.25, 0.5	1, 2.5, 5, 10	15, 30, 50, 100	t
Erreur combinée	Combined error	±0.1	±0.05	±0.1	%Cn
Répétabilité	Repeatability			±0.03	%Cn
Effet de la temp. sur la sensibilité	Temperature effect on sensitivity			±0.005	%Cn/°C
Effet de la temp. sur le zéro	Temperature effect on zero			±0.005	%Cn/°C
Fluage (30 min.)	Creep error (30 min.)			±0.03	%Cn
Plage de zéro initial	Zero balance			±2.5	%Cn
ÉLECTRIQUES	ELECTRICAL				
Plage de tension d'alimentation	Nominal range of excitation voltage			1 ... 15	V
Sensibilité nominale à Cn	Rated output at Cn			2 ±0.15 %	mV/V
Résistance d'entrée/sortie	Input/output resistance			760 ±20 / 700 ±10	Ω
Résistance d'isolement	Insulation resistance			> 2 000	MΩ/50V
GÉNÉRALES	GENERAL				
Plage de temp. compensée	Compensated temperature range			-10 ... +50	°C
Plage de temp. de fonctionnement	Service temperature range			-20 ... +60 ( HT : -20 ... +125)*	°C
Charge limite admissible	Safe load limit	0 ... 10 t :	200 / 15 t ... 100 t :	150	%Cn
Charge ultime avant rupture	Ultimate overload	0 ... 10 t :	400 / 15 t ... 100 t :	300	%Cn
Degré de protection	Protection class			IP68	EN 60529
Matière	Material				
Corps d'épreuve	Measuring body			Inox - Stainless Steel	
Presse étoupe	Cable gland			Inox - Stainless Steel	
Gaine de câble	Cable sheath			PVC (HT : Teflon PFA)	
Longueur du câble	Cable length			10	m
Poids net	Net weight			Voir au recto - See on the front	kg

\* HT : version haute température - High temperature version

## Options - Options

ATEX 2014/34/EU, IECEx  
Uniquement pour version câble - Only for cable version

Ⓢ II 1 G/D, Ex ia IIC T6 Ga, Ex ia IIIC T80°C Da, IP6X, -20°C < Ta < +60°C (zone 0/20)

Ⓢ II 1 D, Ex ta IIIC T125°C Da, IP6X, -20°C < Ta < +60°C (zone 20)

Ⓢ II 3 G, Ex nA IIC T6 Gc, -20°C < Ta < +60°C (zone 2)

Sortie Connecteur - Connector output

M12 - 8 pts

## Accessoires - Accessories

Câble de connexion

Connection cables

M12 8pts, 2/5 m



Kit de montage SILOSAFER - SILOSAFER-R mounting kit



Kit de montage SILOKITR - SILOKITR mounting kit



Kit plaque de montage - Plates mounting kit

# scaime

Siège Social - Headquarter: Technosite Altéa - 294, Rue Georges Charpak - 74100 JUVIGNY - FRANCE

SCAIME SAS - 294, RUE GEORGES CHARPAK - CS 50501 - 74105 ANNEMASSE CEDEX - FRANCE

Tél. : +33 (0)4 50 87 78 64 - Fax : +33 (0)4 50 87 78 46 - info@scaime.com - [www.scaime.com](http://www.scaime.com)

Téléchargez tous nos documents sur notre site internet - Download all our documents on our website